

Plant Protection and Pest Control Using Sensor Based Embedded System

Miss. Shital Shinde¹, Mr. Atul Srivastava²

Abstract—This Paper aimed to investigate an establishment using an Intelligent System which employed an Embedded System and for plant protection and pest control especially of apple using beta regression model. this beta regression model is based on mainly humidity and temperature values. using temperature sensor and humidity sensors real time values in the environment are sensed these values are analyzed and monitored by Raspberry Pi ,With the use of python language beta regression model is implemented in raspberry pi for further action. The result shows that Raspberry Pi and Python successfully predicted the pest attack in advance. In this way it is a novel, easy to handle, economical system for the apple growers and farmers. The system was found to be comfortable for farmers to use as they could effectively control the farm, resulting in cost reduction, asset saving, and productive management in farming.

Keywords—Raspberri pi; Beta regression model; DHT 11; LM35;

I. INTRODUCTION

Prediction depicts the way the things will happen in the future, but not always based on experience or knowledge. Prediction is helpful in various fields and it brings out together the past and current data as a basis to develop reasonable expectations regarding the future. The main objective of this work is to predict the occurrence of risk factor in apple caused by apple scab in Himalayan regions. Firstly, we obtained the readings of the necessary environmental parameters like temperature, humidity and leaf wetness duration, which leads to the growth of disease and pests by interfacing sensors with the Raspberry Pi board and calculation of the infection index of the disease of apple. As a prediction model, the Beta regression model was used as a standard equation from which the severity index was derived and then in the prediction subsystem, the Python programming language was used to predict the severity of apple scab disease to apple caused by ascomycete fungus, *Venturiainaequalis*. Using Python and by analyzing pest surveillance data set of apple scab, we developed a model for the prediction of pests. Further, we used the database connectivity, to send the data and the required outputs to the server where the authorized officials could access the data. The result showed that Raspberry Pi and Python successfully predicted the pest attack in advance. In this way it is a novel,

easy to handle, economical system for the apple growers and farmers. In India

In India almost every farmer uses insecticides and pesticides so as to protect his crops from diseases and pests. They interpret weather on the basis of their experience and when they find a proper time for disease and pest to attack on crop, they spray pesticides to protect their crop from disease and pest attack. Although these chemicals are saving their crop, but soil fertility is decreasing day by day. Inhaling these chemicals may lead to liver disorder, asthma, cancer, etc. Agriculture is one of the most ancient activities of man in which innovation and technology are usually accepted with difficulty, only if real and immediate solutions are found for specific problems or for improving production and quality.

There are many challenges like precision agriculture ,disease forecasting and pest management in the field of farming. Due to pests and disease attacks on the crops ,farmers have to face economic losses every year. To control the pests and diseases, there are many chemical pesticides that are being used by farmers in their fields. Wide spread use of these Agrochemicals has resulted in a damaged agricultural ecosystem, scoring low on product quality and effect on human health. So there is a need of pest management, which is the method to control the pest in an effective manner and reducing our dependence on pesticides. Use of these pesticides can be reduced with the help of forecasting of diseases and pest infections. The Infection rate and disease severity are highly dependent on environmental parameters like temperature, humidity, leaf wetness duration and rainfall, etc. Using correlation of these parameters with the infection rate, a mathematical prediction model is devised to estimate the future value of infection. It predicts risk or no risk for the particular infection to occur on that particular crop [1]. Advance information about severity of risk help to alert the farmers to manage the quality and quantity of pesticides for particular pest and disease. For this work, apple scab has been considered which is infected by fungus.

A. Plant Disease Forecasting

Plant disease forecasting is a system which is used to predict the changes in severity of plant diseases. Such systems are based on assumptions about the pathogenic interactions with the host and the environment; this can be seen in the disease circle *Fig.1*. The objective is to accurately predict the circumstances when the three factors (host, the environment and pathogen) interact in such a fashion that the disease can occur and cause economic losses.

Miss. Shital Shinde, E&TC Department, Vishwabharati Academics College of Engineering, Ahmednagar, (e-mail:shinde204sss@gmail.com), Ahmednagar, India, 9403565010.

Mr. Atul Srivastava, E&TC Department, Vishwabharati Academics College of Engineering, Ahmednagar, (e-mail:atul.srivastava399@gmail.com), Ahmednagar, India, 9860495609.

Host

Environment

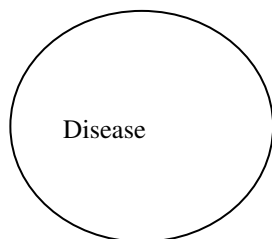

Fig. 1 Disease circle

In most cases, the host can be defined as resistant or susceptible, and the presence of pathogen may often be ascertained based on the foregoing cropping history or perhaps the survey data. The environment is the factor which controls whether the disease would develop or not. The environmental conditions may determine the presence of the pathogen in a particular season through their effects on processes such as overwintering. The environmental conditions also affect the ability of the pathogen to cause diseases, e.g. minimum leaf wetness duration is required for gray leaf spot of corn to occur. Good disease forecasting systems should be well founded, simple, economical and applicable to many diseases. Though, they are normally only designed for diseases that are irregular enough to warrant a disease prediction system, rather than those diseases that occur

every year for which regular treatment should be employed. Forecasting systems can only be designed if there is also an understanding on the actual disease triangle parameters. This low cost system is developed keeping in mind all above things.

II. LITERATURE REVIEW

In paper "Low Cost Sensor Based Embedded System for Plant Protection and Pest Control" authored by Dattatraya Vhatkar Shivling it states that "Prediction depicts the way the things will happen in the future, but not always based on experience or knowledge. Prediction is helpful in various fields and it brings out together the past and current data as a basis to develop reasonable expectations regarding the future. The main objective of this work is to predict the occurrence of risk factor in apple caused by apple scab in Himalayan regions. Firstly, we obtained the readings of the necessary environmental parameters like temperature, humidity and leaf wetness duration, which leads to the growth of disease and pests by interfacing sensors with the Raspberry Pi board and calculation of the infection index of the disease of apple. As a prediction model, the Beta regression model was used as a standard equation from which the severity index was derived and then in the prediction subsystem, the Python programming language was used to predict the severity of apple scab disease to apple caused by ascomycete fungus, *Venturiainaequalis*. Using Python and by analyzing pest surveillance data set of apple scab, we developed a model for the prediction of pests. Further, we used the database connectivity, to send the data and the required outputs to the server where the authorized officials could access the data. The result showed that Raspberry Pi and Python successfully predicted the pest attack in advance. In this way it is a novel, easy to handle, economical system for the apple growers and farmers." [1]

In paper "Electronic Trapping and Monitoring of Insect Pests troubling Agricultural Fields" authored by Dr. S. Thangalakshmi it states that "The impulsively fluctuating climatic conditions and the supplementary effects demand the protection of forestry and cultivation. Pests, bugs and insects are the vital issues that distress the development of crop. Eventually, monitoring and trapping of bugs becomes a more challenging task. The traditional human operators execute surveys of the traps dispersed over the field at regular intervals. This encompasses more work, requires considerable time and is not consistent. It is not effective on economic grounds too. These limitations in the existing systems call for automation with affordable cost. Effective pest trapping will be highly favourable to the farmers while capturing and sending the images of pests will be helpful for further analysis in agricultural fields. Moreover, this will be definitely helpful in reducing the usage of pesticides since automatic trapping is efficient and effective. An electronic trap for pest insects by an autonomous monitoring system using black lights (Ultra Violet) and LED lights is suggested in this paper. A statistical analysis is made on the probable time of high pest population and a trap with three layers of different thickness is designed to capture various sizes of prominent pests. A low-cost image sensor is used to capture the images of trapped pests and the images are sent to a remote control station. The information thus acquired enhances the estimation of pest concentrations in farms. The entire analysis is carried out in paddy and brinjal fields and is supported by MSSRF (M S Swaminathan Research Foundation), Chennai." [2] In paper "Embedded based Remote Control Application using Mobile Phone in Irrigation" authored by S. Sumeetha it states that "This paper provides the development of mobile phones as remote control application for the induction motor-pump which is used in the agriculture for irrigation. Due to frequent power cuts and abnormal voltage conditions in India, it is necessary to distribute water efficiently to the fields during normal conditions. This is carried out by exchanging the information between the user phone and GSM in the form of missed calls and messages.

This system is developed with PIC16F877A Microcontroller which is connected to the GSM, sensors and the motor. The temperature sensor is used to detect the temperature of the environment and capacitive sensor to sense the water flow in the pipe. The microcontroller includes the protection against over-current, dry running and single phasing. It is expected that this application provides easy access of motor to a great extent." [3] In paper "Microcontroller based adaptive irrigation system using wsn for variety crops and development of insect avoidance system for better yield" authored by patil kalikamilindit states that "Agriculture is main source of livelihood of people. it provides food as well as large employment. so modernization of agriculture is important because traditional farming is unable to boost up the crop yield. therefore farmer start to utilize the various technology to achieve better yield and reduce the required man power. water is a precious natural resource, a basic human need and a prime national asset. rapid development of human civilization and advances of scientific and technological innovations are changing the condition of life on earth, giving rise to basic transformations of environment. in india, the growth of population is about 2% per year. it is essential that food production should increase about 2.5% per year to provide a better food intake. the available water

resources are to be optimally connected and beneficially utilized with appropriate priorities of use. therefore the real time values of soil moisture, air humidity, temperature and water level in the soil are wirelessly transmitted using wireless technology. at the same time, the pest and diseases have increased and insects are responsible for major kinds of damage to growing crops. it directs injury to the plant, which eats leaves or fruit, or roots. most vegetable crops are subject to pest damage. so protection from insect attack to the crop is essential for better production. " [4]In paper " Arm Based Automated Wireless Greenhouse Climate Management System Using Zigbee Technology " authored by ZoyaParvez S it states that " Increases in greenhouse sizes have forced the growers to increase measurement points for tracking changes in the environment, thus enabling energy saving and more accurate adjustments. However, increases in measurement points mean increases in installation and maintenance cost. The purpose of this project "Auto-mated wireless greenhouse climate management system" which is capable of intelligently monitoring and controlling the greenhouse climate conditions in a pre programmed manner. The proposed system consists of three stations: Sensor Station, Coordinator Station, and Central Station. To allow for better monitoring of the climate condition in the greenhouse, the sensor station is equipped with several sensor elements such as CO₂, Temperature, humidity, light, soil moisture and soil temperature. The communication between the sensor station and the coordinator station is achieved via ZigBee wireless modules and the communication between coordinator station and the central station is achieved via Zigbee wireless modules. The overall system architecture shows advantages in cost, size, power, flexibility and distributed intelligent. It is believed that the outcomes of the project will provide the opportunity for further research and development of a low cost automated wireless greenhouse management system for commercial use." [5]

III. SYSTEM DEVELOPMENT

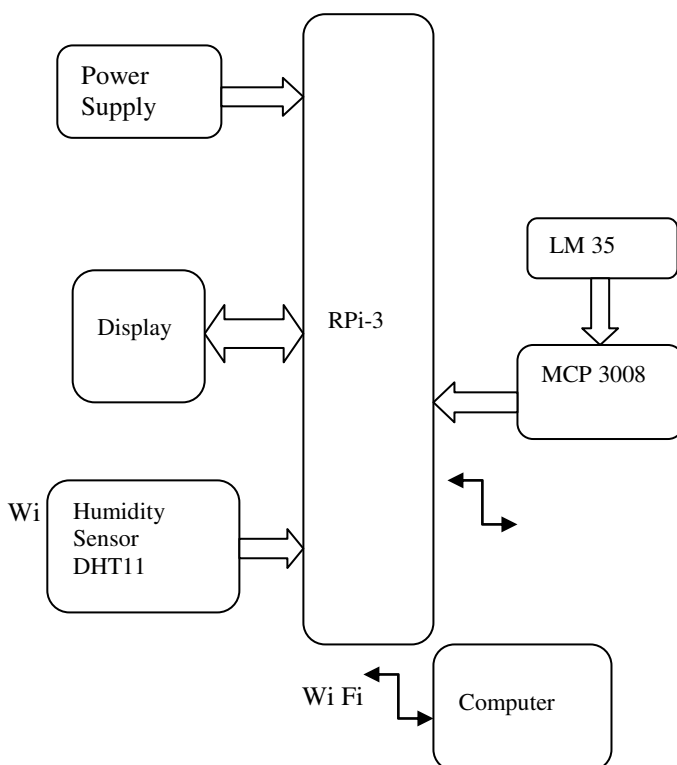

Fig.2 Work Flow of System

ARM 11 is chief system in our project. This is used to control, monitor and decision making for application. For ARM 11 we are using raspberry pi. Raspberry Pi hardware has evolved through several versions that feature variations in hardware performance, memory capacity, and peripheral device support.

Processor

The SoC used in the first generation Raspberry Pi is somewhat equivalent to the chip used in older smartphones (such as iPhone / 3G / 3GS). The Raspberry Pi is based on the Broadcom BCM2835 system on a chip (SoC), which includes an 700 MHz ARM1176JZF-S processor, VideoCore IV GPU, and RAM. It has a Level 1 cache of 16 KB and a Level 2 cache of 128 KB. The Level 2 cache is used primarily by the GPU. The SoC is stacked underneath the RAM chip, so only its edge is visible.

Performance of first generation model

While operating at 700 MHz by default, the first generation Raspberry Pi provided a real world performance roughly equivalent to 0.041 GFLOPS. On the CPU level the performance is similar to a 300 MHz Pentium II of 1997-1999. The GPU provides 1 Gpixel/s or 1.5 Gtexel/s of graphics processing or 24 GFLOPS of general purpose computing performance. The graphics capabilities of the Raspberry Pi are roughly equivalent to the level of performance of the Xbox of 2001.

The LINPACK single node compute benchmark results in a mean single precision performance of 0.065 GFLOPS and a mean double precision performance of 0.041 GFLOPS for one Raspberry Pi Model-B board. A cluster of 64 Raspberry Pi Model-B computers, labeled "Iridis-pi", achieved a LINPACK HPL suite result of 1.14 GFLOPS (n=10240) at 216 watts for c. US\$4,000.

Raspberry Pi 2 is based on Broadcom BCM2836 SoC, which includes a quad-core Cortex-A7 CPU running at 900 MHz and 1 GB RAM. It is described as 4–6 times more powerful than its predecessor. The GPU is identical.

SENSORS:

As shown in block diagram three sensors are used they are :

- i. Temperature sensor
- ii. Humidity Sensor

Outputs of sensors are fed to raspberry pi v. the respective sensors value are shown on web page using IOT application LM 35 and DHT11 are used to generate real time temperature and humidity values. these values are going to be used by beta regression model for disease forecasting.

MCP 3008 is used as analog to digital converter.the temperature data from LM35 is in analog form.this analog data is fed to ADC. ADC MCP 3008 converts analog data in to digital data and feed it to the raspberripi.Power supply used for ARM 11 is of 12V and .7 A. it's a Standard adapter come along ARM 11.

All controlling and monitoring of data in this project is done by web page. for development of webpage we are using php system.

BETA REGRESSION MODEL

The generalized equation of the beta regression model is used for the forecasting of disease in Apple for this work:

$$y = \alpha t^\beta (1-t)^\gamma H^\delta \tag{1}$$

Where y is the disease severity index, alpha, t, beta and gama are unknown parameters estimated from the data, H is the Relative Humidity and $t = (T - T_{min}) / (T_{max} - T_{min})$ (2)

which is a scaled version of temperature defined by the minimum and maximum temperatures for infection (Tmin and Tmax, respectively). The parameter beta describes how steeply y increases with increasing T up to the optimum, the parameter Gama describes how steeply y decreases as T increases past the optimum. The severity index ranges from 0 to 1. Table I. Severity Index Ranges

Table I. Severity Index Ranges

Range of Y	Severity index
<0.5	Low risk
0.5<Y<1	Moderate risk
>1	High risk

The above equation can be linearized to:

$$\log(y) = \log(\alpha) + \beta \log(t) + \gamma \log(1-t) + \delta \log(H) \tag{3}$$

At the time of programming of the Raspberry Pi board, the display unit, keyboard and mouse are connected with it. When the programming task is over these accessories are not needed and the whole system can be accessed at a distant location by using SSH (Secure Shell) by only enabling the SSH on the Raspberry Pi board and installing software on the distinct system that is being used to control the board . For connecting the ADC with the Raspberry Pi board, SPI (Serial Peripheral Interfacing) programming is needed to be done. Programming of ADC, sensors is done in Python Software. Python is one of those rare languages which can claim to be both simple and powerful. Python is an easy to learn, programming language. The output signals of the sensors are conditioned and interfaced and then by using the beta regression model the severity index of the Apple for scab disease is calculated and then the calculated parameters are sent to the server. For sending the data to the server, first of all the database is needed to be created.

IV. CONCLUSION

The proposed system implemented using embedded system. it shows impactful results over plant protection and pest control. The implemeted system over raspberri pi, Different sensors like LM 35 and DHT11 shows satisfactory waorking. The webpage implemented using php language updates value very well to have better monitoring and control using Wi -FI. The system over long run will play important role in plant protection and pest control.

ACKNOWLEDGMENT

I would like to thank my college VACOE staff for supporting me to implement project over Plant protection and pest control. Without them it was not possible to do such a impactful work.

REFERENCES

[1]Manivannan M and Kumaresan N "Embedded web server& GPRS based Advanced Industrial Automation using Linux RTOS" /International Journal of Engineering Science and Technology Vol. 2(11), 2010, 6074-6081

[2] Clyde C. W. Robson, Samuel Silverstein, and Christian Bohm (2008) An Operation-Server Based Data Acquisition System ArchitectureIEEE Transaction on Nuclear Science, Vol. 55, No.1.

[3] Du.Y, and Liu.C, (2007) Testing Method for Embedded Real-time System Software Control & Automation, Vol. 23, No. 4-2, pp. 86-88.

[4] Ian S. Schofield, David A. Naylor, (2000) —Instrumentation Control Using the Rabbit 2000 Embedded Microcontrollerl, AstronomicalInstrumentation Group, Department of Physics, University of Lethbridge, 4401 University Drive West, Lethbridge, Alberta, T1K 3M4, Canada

[5] Jin.M, Zhou.X, and Jin.L,(2007) Embedded System: components, Principles, Design and Programming, Posts & Telecom Press, China,

[6] KrithiRamamritham, John A. Stankovic, (1994) Scheduling Algorithms and Operating Systems Support for Real-Time Systems, Proceedings of IEEE, vol. 82, No. 1, pp. 55-67.

[7]Li.S,Jiarong.R.Luo,Yichun.C.Wu,Guiming.M.Li,FengWang,and YongWang,(2010)Continuous and Real-Time Data Acquisition Embedded System for EAST IEEE Transaction on Nuclear Science,Vol.57,No.2,

[8] Li J,Zhang B, Qiu D.Y, (2007) Multi-computer communication based on Modbus RTU in power quality monitoring system. Electric Power Automation Equipment, Vol.27,(1):93-96.

[9] Peng D.G, Zhang.H, Jiang.J.N. (2008) Design and Realization of Embedded Web Server Based on ARM and Linux. Mechatronics, Vol.14(10):37-40.

[10] Silverstein.S.B, Rosenqvist.J, and Bohm.C,(2006) A simple Linux-based platform for rapid prototyping of experimental control systems,IEEE Transaction on Nuclear Science vol. 53, no. 3, pp. 927–929.

Miss. Shital Shinde ,pursuing ME in VLSI and Embedded System at VACOE Ahmednagar, India.

Mr. Atul Srivastava completed ME in VLSI and Embedded System and working as Assistant Professor of Electronics and telecommunication Departmentat Vishwabharati Academy’s college of Engineering Ahmednagar, India.