

IOT based Smart Farm Monitoring Using Raspberry PI and Arduino Uno

Miss. Supriya Kale, Mr. P Balaramudu, Mr. Manoj Kumar Singh

Abstract—This Paper is aimed to implement Intelligent System that uses a Linux based webserver with Embedded System for smart farm monitoring using Raspberry Pi and Arduino Uno. The proposed system outcomes will be monitoring and control of environmental condition at farm. As well as it will show serial peripheral communication & USB protocol communication between Raspberry Pi and Arduino Uno. In proposed system Raspberry pi is used as Embedded Web server & Arduino Uno is used to Read sensor value. With Embedded Web Server system Internet of thing system is implemented.. The findings of this study found that the system may monitor Combine climate as well as wetness, temperature, climate quality, The system was found to be impactful for farmers to use as they may effectively manage the farm at remote area as well, leading to price reduction, quality saving, and productive management in target farming

Keywords—Raspberry Pi ; Arduino Uno; Webserver ; DHT11;

I. INTRODUCTION

The primary function of a web server is to store, process and deliver web pages to clients. The communication between client & server takes place by using the Hypertext Transfer Protocol (HTTP). Pages delivered are most frequently HTML documents, which may include images, style sheets and scripts in addition to text content.

A user agent, commonly a web crawler or web browser, originates communication by making a request for a specific resource using HTTP and the server responds with the content of that resource or an error message if unable to do so. The resource is basically a real file on the secondary storage of the server, but this is not essential the case and only depends on how the web server is implemented.

While the primary function is to serve content, a full implementation of HTTP also includes ways of receiving content from clients. For submitting web forms, including uploading of files this feature is used. Many generic web servers also support server-side scripting using Active Server Pages (ASP), PHP, or other scripting languages.

This indicates that the nature of the webserver can be scripted in separate files. while the actual server software remains unchanged. Usually, this function is used to generate HTML documents dynamically ("on-the-fly") as opposed to returning static documents. While the actual server software remains unchanged. The former is initially used for modifying and/or retrieving information from databases. The latter is

typically much faster and more easily cached but cannot deliver dynamic content.

Web servers are not always used to serve the (WWW) World Wide Web. They can also be found embedded in devices such as printers, routers, webcams and serving only a local network. The web-server may then be used as a part of a system for administering and/or monitoring the device in question. This usually means that no additional software has to be installed on the client computer, since only a web browser is required (which now is included with most operating systems).common features of web server includes:

- Virtual hosting to serve many web sites using one IP address
- Large file support to be able to serve files whose size is greater than 2 GB on 32 bit OS
- To limit the speed of responses in order to unsaturated the network and to be able to serve many clients by Bandwidth throttling.
- Server-side scripting to generate dynamic web pages, still keeping web server and website implementations separate from each other

In proposed project we are using web server to access different sensors data as well as to control different Farm applications for power management purpose.

Without web servers the internet as we know it would cease to exist. Web-servers are an unavioded part of the way the internet works. The web hosting industry is simply used to lease out web servers, providing average business owners and individuals with the opportunity to use high-tech servers that make it possible to expand their outreach to the entire world. Without rental web servers the internet would be a fraction of the size it is today, as most web site owners can afford to buy their own web server in cash.

Web servers are the gateway between the average individual and the world wide web.

II. LITERATURE REVIEW

This analysis has targeted on the employment of recent technology to assist manage animal farming, which implies farm management automation in numerous ways that. ManakantIntarakamhaeng and et al [4] studied the model of farm management computerization tools with RFID, Result; the approval of RFID, or radio-frequency identification of

objects and animals as well as five sorts of animal: oxen, buffalo, sheep, pigs and rabbits were with success singly known and recorded mechanically. MdSaifudaulah Bin Bahrudin and Rosni Abu Kassim [5] conferred fireplace warning device in a very period observance system that detected the presence of smoke within the air attributable to fire and captured pictures via a camera put in within an area once a hearth happens. The embedded systems accustomed develop this hearth warning device were Raspberry Pi and Arduino. The key aspect of the system is that the ability to remotely send AN alert once a hearth is detected. Once the presence of smoke is detected, the system can show a picture of the space state in a very website. The system can would like the user confirmation to report the event to the fire-eater employing a Short Message Service (SMS). The advantage of mistreatment this method is that it'll call back the chance of false alert according to the fire eater. The camera can solely capture a picture, thus this method can consume solely slightly storage and power. Kumar associate degreed Hancke [6] given an animal health observation System (AHMS) for observation the physiological parameters

A. Web Server

A web server is an information technology that processes requests via HTTP, the basic network protocol used to distribute information on the World Wide Web. The term can indicate either to the whole computer system & an appliance, or specifically to the software that accepts and supervises the HTTP requests. The process is an example of the client/server model. All computers that host Web sites should contain Web server programs. Leading Web servers include Apache (the most widely-installed Web server), Microsoft's Internet Information Server (IIS) and nginx (pronounced *engine X*) from NGINX. Other Web servers includes Google, Novell's NetWare server, Google Web Server (GWS) & IBM's family of Domino servers. Web servers often come as part of a larger package of Internet- and intranet-related programs for serving email, downloading requests for File Transfer Protocol (FTP) files, and building and publishing Web pages. Considerations in choosing a Web server must consider that how better it works with the operating system (OS) and other servers, its ability to handle server-side programming, security characteristics, and the particular publishing, search engine and site building tools that come with it. Web server means every Website sits on a computer. This server is always connected to the internet. Every Web server that is connected to the Internet is given a unique address made up of a series of four numbers between 0 and 255 separated by periods. For example, 68.178.157.132 or 68.122.35.127.

When you register the address of the web, which is also known as a domain name, like tutorialspoint.com you have to specify the IP address of the Web server that will host the site.

There are four leading web servers – Apache, IIS, lighttpd and Jigsaw. Now we will see these servers in bit more detail. Apart from these Web Servers, there are other Web Servers also available in the market but they are very expensive. Major ones are Netscape's iPlanet, Bea's Web Logic and IBM's WebSphere.

In the absence of web servers the internet as we know it would cease to exist. Web servers are an integral part of the way the internet works. The web hosting industry is basically used to lease out web-servers, giving average business owners and individuals with the opportunity to use high-tech servers that make it possible to expand their outreach to the entire world. Without rental web servers the internet would be a fraction of the size it is today, as most web site owners can afford to buy their own web server in cash.

Web servers are the gateway between the (WWW) World Wide Web and average individual. Keeping in mind all these necessities we are using web server to show controlling and monitoring of different data.

B. Raspberry Pi

Raspberry Pi [7] is a small computer board working on the Linux operating system which connects to a computer monitor, keyboard, and mouse. Raspberry Pi can be applied to

a electronic structure and programming network work, it can also served as a personal computer and Apache Webserver, MySQL could be installed in the board. A GPIO [10] pin can be used as either a digital input or a digital output, and both operate at 3.3V. Unlike the Arduino, the Raspberry Pi which does not have any analog inputs. For that you should use an external analog-to-digital converter (ADC) otherwise connect the Pi to an interface board must be used.

C. Arduino

Arduino is an open-source microcontroller compatible with developed platforms. The controller appears not to be expensive and uses low electrical power, 5.5 volts. C and C++

were employed for this development. Arduino can connect to a computer via the Universal Serial Bus (USB) and perform with compatible connected accessories in both analog signal and digital signal. The Arduino [7] is a microcontroller platform, mounted on a board that plugs easily into most computers.

D. Gas sensor :

MQ-135 gas sensor module are used in gas leakage detecting equipments in family and industry, are suitable for detecting of LPG, i-butane, propane, methane, alcohol, Hydrogen, smoke. it has following features :

- i. Fast response
 - ii. Adjustable sensitivity
 - iii. Covers LPG, i-butane, methane, alcohol, Hydrogen etc
- Useful for gas leakage detecting Grove connector compatible

E. Humidity sensor

A humidity sensor senses, measures and regularly reports the relative humidity in the air. It measures both moisture and air temperature. Relative humidity, expressed as a percent, is the ratio of actual moisture in the air to the highest amount of moisture air at that temperature can hold. The warmer the air is, the more moisture it can hold, so relative humidity changes with fluctuations in temperature.

F. LDR

A Light Dependent Resistor(LDR) or a photo resistor is a device whose resistivity is a function of the incident electromagnetic radiation. Hence, they are light sensitive devices. They are also called as photo conductors, photo conductive cells or simply photocells. They are made up of semiconductor materials having high resistanc

III. SYSTEM DEVELOPMENT

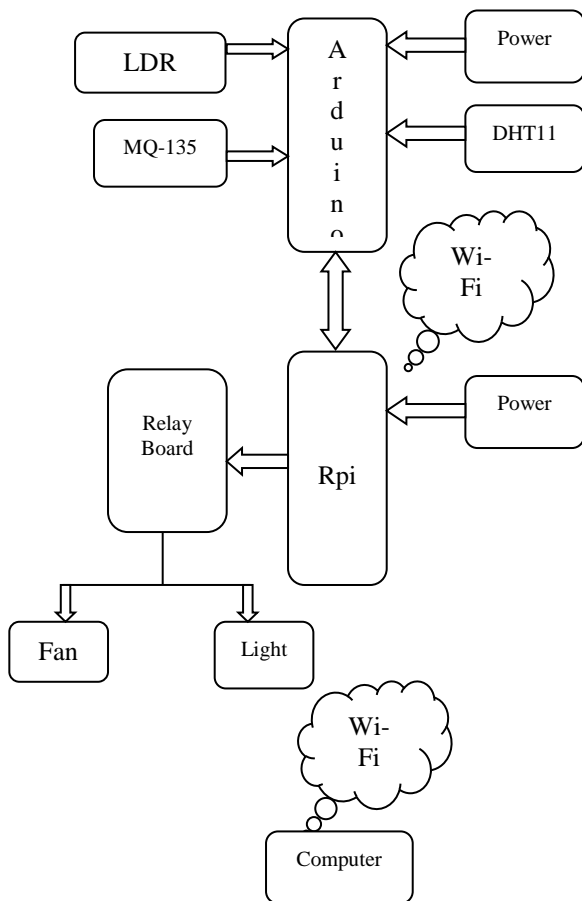

Fig. 1 Block Diagram

ARM 11 is chief system in our project. This is used to control, monitor and decision making for application. For ARM 11 we

are using raspberry pi. Raspberry Pi hardware has evolved through several versions that feature variations in hardware performance, memory capacity, and peripheral device support.

The SoC used in the first generation Raspberry Pi is somewhat equivalent to the chip used in older smartphones (such as iPhone / 3G / 3GS). The Raspberry Pi is based on the Broadcom BCM2835 system on a chip (SoC), which includes 700 MHz ARM1176JZF-S processor, VideoCore IV GPU, and RAM. It has a Level 1 cache of 16 KB and a Level 2 cache of 128 KB. The Level 2 cache is used primarily by the GPU.

Performance of first generation model

While operating at 700 MHz by default, the first generation Raspberry Pi provided a real world performance roughly equivalent to 0.041 GFLOPS. On the CPU level the performance is similar to a 300 MHz Pentium II of 1997-1999. The GPU provides 1 Gpixel/s or 1.5 Gtexel/s of graphics processing or 24 GFLOPS of general purpose computing performance. The graphics capabilities of the Raspberry Pi are roughly equivalent to the level of performance of the Xbox of 2001.

The LINPACK single node compute benchmark results in a mean single precision performance of 0.065 GFLOPS and a mean double precision performance of 0.041 GFLOPS for one Raspberry Pi Model-B board. A cluster of 64 Raspberry Pi Model-B computers, labeled "Iridis-pi", achieved a LINPACK HPL suite result of 1.14 GFLOPS (n=10240) at 216 watts for c. US\$4,000.

Raspberry Pi 2 is based on Broadcom BCM2836 SoC, which includes a quad-core Cortex-A7 CPU running at 900 MHz and 1 GB RAM. It is described as 4–6 times more powerful than its predecessor. The GPU is identical.

SENSORS:

As shown in block diagram three sensors are used they are :

- i. Gas sensor
- ii. Light sensor
- iii. Humidity Sensor

Output of sensors is fed to raspberry pi via Arduino. The respective sensors values are shown on web page using IOT application.

Light Sensor:

It is used to sense intensity of light. According to intensity level sensing respective signal is sent to ARM 11 which in turn to be displayed on web page.

Gas sensor:

This is a simple-to-use liquefied petroleum gas (LPG) sensor, suitable for sensing LPG (composed of mostly propane and butane) concentrations in the air. The MQ-135 can detect gas concentrations anywhere from 200 to 10000ppm.

This sensor has a high sensitivity and fast response time.

The sensor's output is an analog resistance. The drive circuit is very simple; all you need to do is power the heater coil with 5V, add a load resistance, and connect the output to an ADC.

Power supply used for ARM 11 is of 12V and .7 A. it's a Standard adapter come along ARM 11. All controlling and monitoring of data in this project is done by web page. for development of webpage we are using php system.

IV. RESULT AND CONCLUSION

The implemented system has been tested over farm. it is been found that system is working very well, The main component of the system like arduino and raspberri pi are communicating well with each other for sensor value readings. The sensor values are well read by webpage using webserver system. This system has valuable and impactful role in smart farm monitoring. This system will be definitely Lighthouse for further research over smart farming.

REFERENCES

[1] G. Eason, B. Noble, and I.N. Sneddon, "On certain integrals of Lipschitz-Hankel type involving products of Bessel functions," *Phil. Trans. Roy. Soc. London*, vol. A247, pp. 529-551, April 1955. (references)

[2] J. Clerk Maxwell, *A Treatise on Electricity and Magnetism*, 3rd ed., vol. 2. Oxford: Clarendon, 1892, pp.68-73.

[3] I.S. Jacobs and C.P. Bean, "Fine particles, thin films and exchange anisotropy," in *Magnetism*, vol. III, G.T. Rado and H. Suhl, Eds. New York: Academic, 1963, pp. 271-350.

[4] K. Elissa, "Title of paper if known," unpublished.

[5] R. Nicole, "Title of paper with only first word capitalized," *J. Name Stand. Abbrev.*, in press.

[6] Y. Yorozu, M. Hirano, K. Oka, and Y. Tagawa, "Electron spectroscopy studies on magneto-optical media and plastic substrate interface," *IEEE Transl. J. Magn. Japan*, vol. 2, pp. 740-741, August 1987 [Digests 9th Annual Conf. Magnetism Japan, p. 301, 1982].

[7] M. Young, *The Technical Writer's Handbook*. Mill Valley, CA: University Science, 1989.

Miss. Supriya Kale Completed B.Tech Electronics & Now Pursuing ME In VLSI and Embedded system at SVCET,Rajuri,Maharashtra,India.
Email Id.kale.supriya12@gmail.com

Mr. P Balaramudu Completed ME , Now Working As an Assistant Professor in E&TC deoartment at SVCET,Rajuri,Maharashtra,India.
Email Id. balram9hossanna@gmail.com

Mr. Manoj Kumar Singh Completed ME In Digital Electronics, Working As an Assistant Professor in E&TC deoartment at SVCET,Rajuri,Maharashtra,India.
Email Id. manojkumar1985.111@rediffmail.com